

## Magnum Trailer

### TITAN 2000 EASY LIFT

-Setup and Adjustment-

Setup and adjustment of the Titan 2000 Easy Lift is quite straight forward when the proper procedures are followed. However please read the following carefully.

#### **-WARNING – Safety First –**

Follow directions to ensure personal safety when working on Titan 2000 Easy Lift. This device uses a strong spring, which stores high forces. Do not remove bumper pivot bolts or Easy Lift fasteners without releasing the preload of the unit. **Do not remove bumper from truck without relaxing preload.**

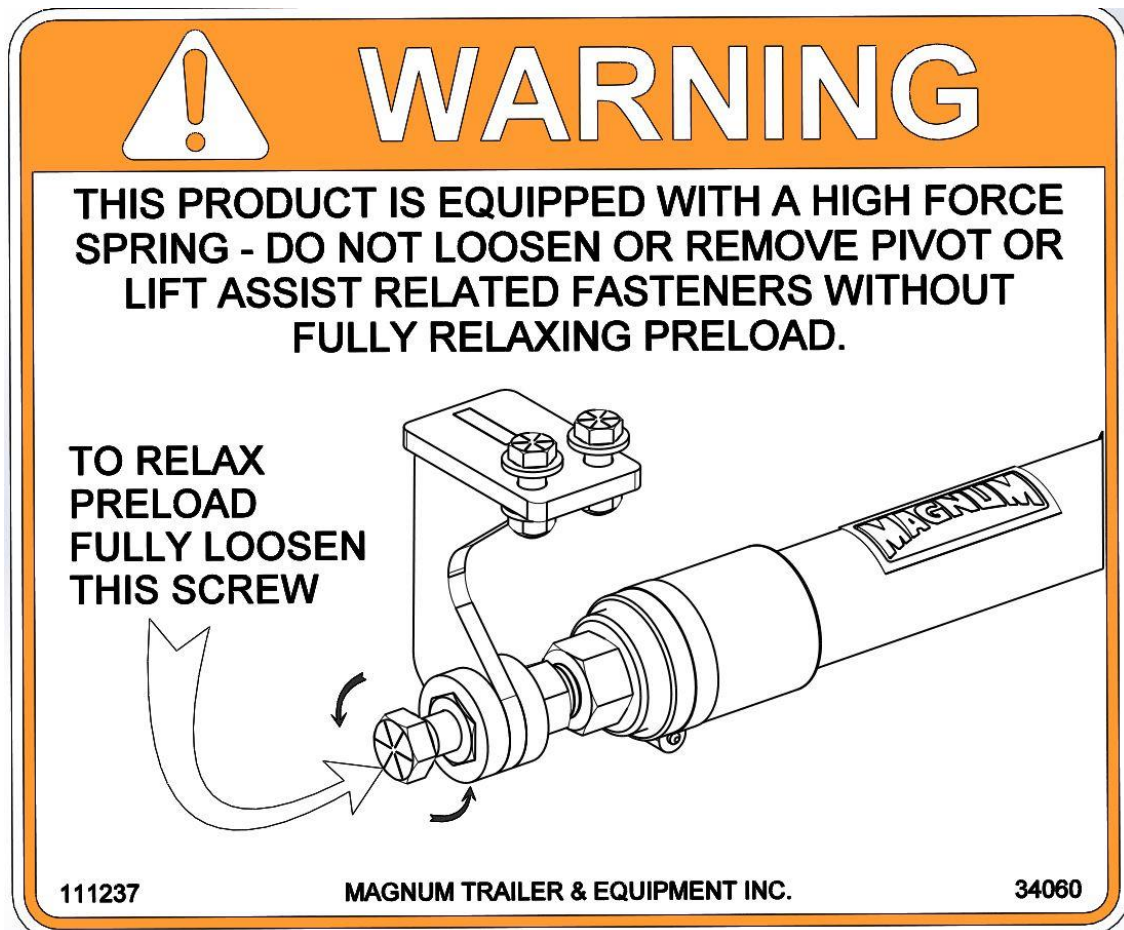

## Titan 2000 Easy Lift Instructions

### To preload Unit for use:

Preloading the Titan 2000 is best performed with the help of an assistant. Work is carried out from below the truck, accessing the back of the bumper. See Fig. 1

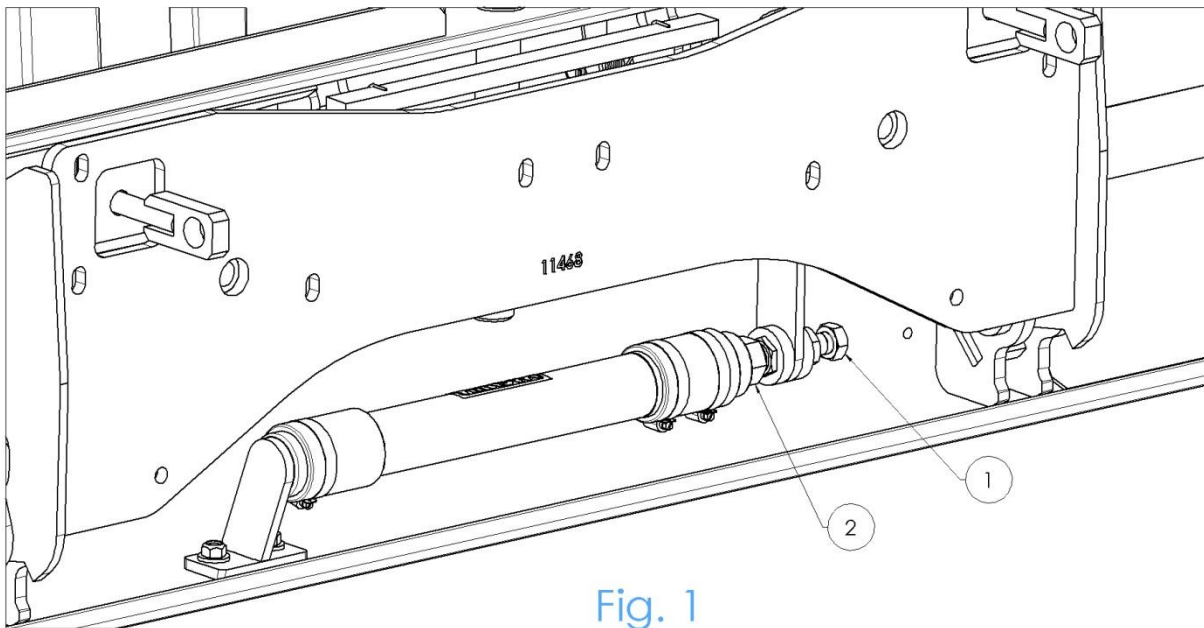

Fig. 1

Locate and identify the Locking Screw - Item 1 and the Adjusting Nut - Item 2. From the back of the bumper, they are located toward the right side. Fig. 1 shows a Magnum bumper, which measures 18 ½" high on the front face. The arrangement for Magnum bumpers using the 12" beam is similar, except the Easy Lift unit is *below* the bottom flange of the bumper. Adjustment of both types is the same.

### **CAUTION**

**Make sure the truck is parked with the engine switched off, and the brakes are applied.**

**Block wheels to prevent any possibility of the vehicle moving.**

**Remove keys to prevent the truck from being driven by someone unaware that workers are under the truck.**

To preload Unit for use: con't.

Begin with the bumper in the up (closed) position. A 1 ½" open end wrench is required to turn Adjusting Nut – Item 2, and a 1 1/8" socket (preferred) or wrench is needed to turn the Locking Screw – Item 1.

From below the truck and accessing the rear of the bumper, turn Adjusting Nut in the direction shown in Fig. 2. As the Adjusting Nut is rotated, the Locking Screw should be screwed in to prevent the Adjusting Nut from turning back. As note earlier, it is very helpful to have an assistant tighten the Locking Screw. Continue turning the Adjusting Nut, and tightening the Locking Screw until approximately 1/3 to 1/2 of a turn of preload is applied.

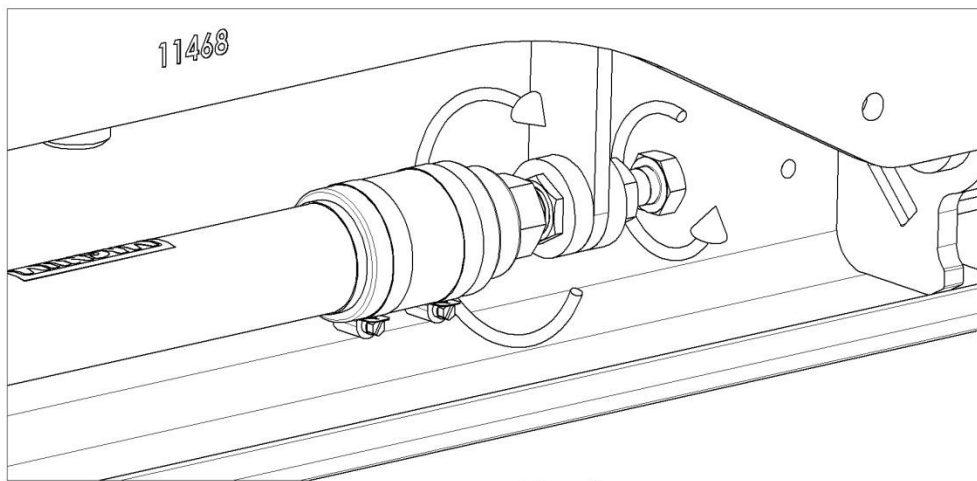

Fig. 2

At this point the preload should be checked by clearing the underside of the vehicle of workers and equipment, and opening the bumper. As the bumper is lowered, a reduction in weight of the bumper should be noticed. If the bumper does not open fully under its own weight, the preload is too high and must be reduced. *See below to reduce preload.*

Do not force the bumper down – damage to Lift Assist will occur. It is normal to need to pull on the closed bumper to begin opening it; however once it is about half way open it should begin to drop under its own weight.

If the bumper stays fully down under its own weight but does not feel as light as desired when open, preload a further 1/6<sup>th</sup> of a turn, and recheck. Repeat increase preload and check steps until operation is satisfactory.

**\*\*NOTE:** It may be best to keep some “weight” on the bumper when open to prevent unintentional closing due to wind or other forces. Never operate with a preload that prevents the bumper from staying fully down under its own weight.

To release preload for Adjustment or Service Work:

Relaxing the preload of the Lift Assist fully is required for the following:

- Installation or removal of the bumper. **This is very important particularly when removing the bumper from the truck.**
- Removal of the Aluminum assembly from the Steel assembly.
- Any work performed on the Lift Assist mounting fasteners.

Partial relaxing of the preload must be performed if the bumper does not stay fully down under its own weight. The preload may also be partially relaxed to adjust the operation of the bumper ie. – to prevent the bumper from blowing shut in windy conditions, or for safety around small children or pets.

To relax the Lift Assist preload, simply loosen the Locking Screw. This will require a high amount of force on the wrench. A “cheater bar” on the wrench is very helpful. To fully relax the preload continue to loosen the screw until it is free, with the bumper down.

**\*\*The bumper may be safely operated with the preload relaxed if necessary.\*\***

*The Lift Assist unit requires no maintenance, however mounting fasteners should be visually inspected from time to time for tightness.*